

# Portable Massage Table Construction Plans



**Note: Picture is similar design but not exactly this table.**

**Developed June 1997**

**Last modified on Monday, February 7, 2005 to add Imperial to Metric  
Conversion table**

**This is a drawing of the table!**

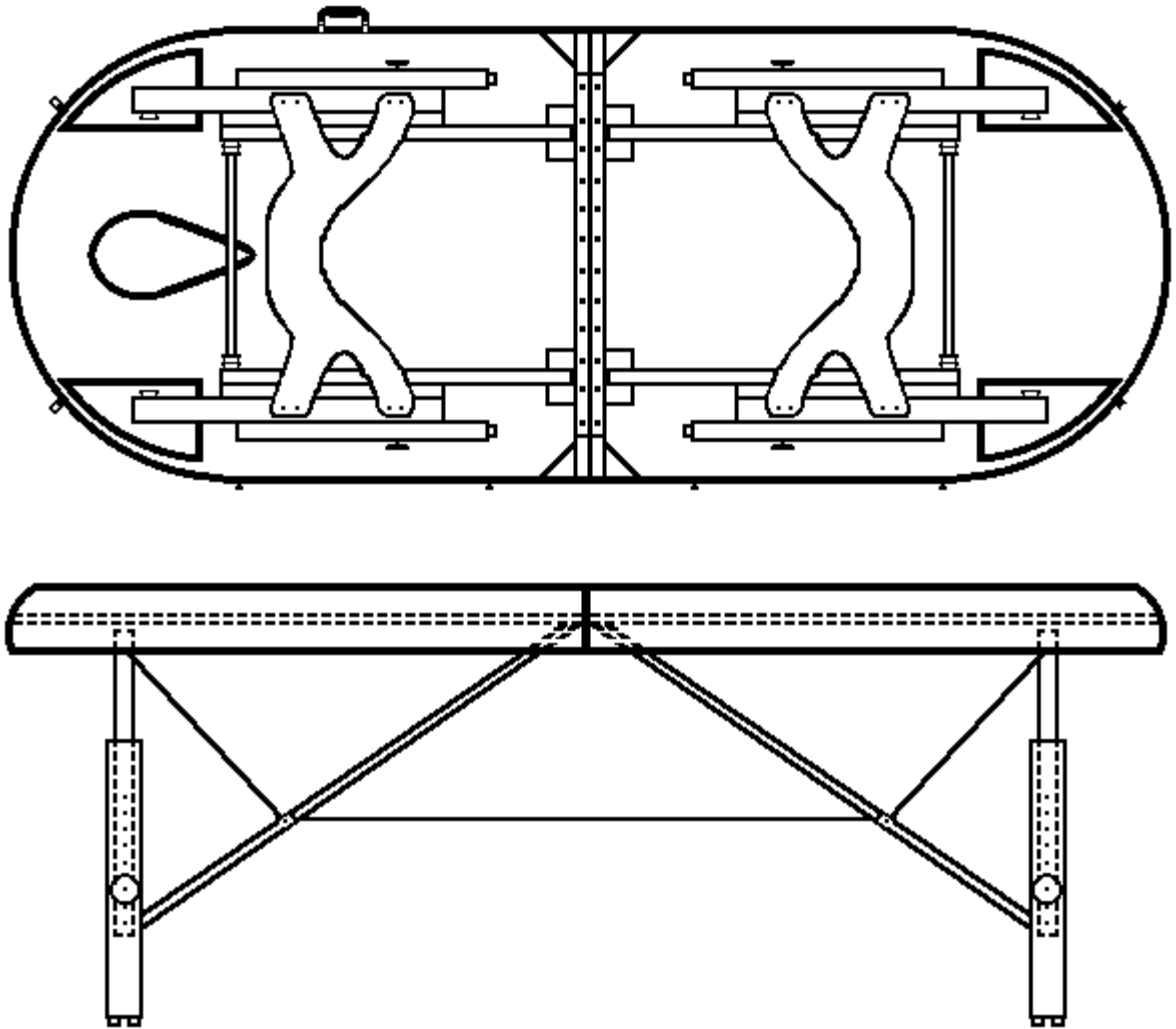

## Overview

### *Summary:*

This still evolving page provides a complete set of plans to help someone with good woodworking knowledge, a full set of tools and clamps, and about \$235 to build an exceptional, light weight, strong, portable massage table that is suitable for doing healing treatments and massage. This is not a particularly difficult project if you stay organized and are careful. It takes about forty hours of woodworking, finishing, cable making and upholstery to complete. For those without the tools, skills, or time to build their own table look at my sponsor and look at both [SAM's Club](#) and at [COSTCO](#) discount warehouses as they each sell workable massage tables for under \$200 (US). If funds are a concern, I also found a table you can convert into a massage table for under \$80 (US). Click [here](#) for more details. Finally, many are saying this page is an

excellent source of information that helped them buy a better portable massage table.

### ***Thank You!***

When I started this site in 1997 to give thanks to the many in our healing community who helped me get through my own health challenges I had no idea how much positive interest it would generate. The interest has been incredible with many sharing their thanks and improvement suggestions. As time permits I have used those generous suggestions to help evolve this design from my early, inefficient efforts into a far better plan that is less expensive, easier, and faster to build. Moreover, this feedback has provided more information to help people make a more informed decision when buying a portable massage table. I sincerely thank all of you who have been so supportive and hope that you enjoy!

### ***Disclaimer:***

This site was built as a gift with no intent to criticize any firm or steal anyone's work. To a degree, this site reflects the old adage that "No good deed goes unpunished". Since putting up this site I've been threatened, harassed, and twice attacked by attorneys.

The first attack was utterly ridiculous. I designed a very nice simple background for this site of a balloon figure giving a massage. A massage organization attorney threatened to sue because the web designer for that firm lifted my background design and they got it registered as their trademark. I showed the attorney that their design still had my name and date in the created by field in the image on their site, and they still persisted. My own attorney explained that I had to locate their web designer, sue them, win a judgment, then sue the massage association. Roughly \$40K and two to five years later I would again be able to put back on this site the background I designed. He said there was little to no chance that I could recover anything from the web designer and zero chance of being able to recover anything but attorney fees for the second suit from that massage organization. I conceded acknowledging they found a "legal right" to steal my work.

Next, I was threatened with a lawsuit over patent infringement. The cost to get a legal opinion nearly took this site down permanently, but a group of patent attorneys was willing to assist. They found no such patent held by the complainer. They found all design elements used in this table have been common woodworking and cable rigging practices for far longer than the duration of any single patent. There is one table that is similar and patented. They then explained that patents are issued when someone comes up with a unique idea or unique design. Because my significant improvements in the manufacture of the table skirt creates a stronger lighter table, they felt confident that they could get this design patented for me if I wanted to do so. I explained I wanted this site to simply be a gift back to the healing community who helped me so much in my own trials. They assured me that even if this

site was a total copy of a patented table, which it is not, that by law and long legal precedent I had a right to share the information as all information in the U.S. Patent Office is public information to share. They also said anyone who would like to build their own table for their own personal use from these plans or any other plans they find has a right to do so without paying anyone. If you want to use this design to make massage tables for sale, they suggest you work with an attorney to avoid possible patent infringement.

### ***Order Requests:***

Many who have seen this site and many who have seen my table and tables that I helped my students build, have asked me to build them a custom table. Although I wish I could build a table for all that want one, I must continue to say no to all requests. I have a bad leg that limits me to at most an hour or two a week in my shop and far too many higher personal priorities for that limited time. Moreover, this is my hobby and I do not want to turn it into a business.

### ***Background:***

As an old engineer, computer nerd, woodworker, Shiatsu Master and Reiki Master, I have been using massage tables since starting my healing training in Japan in the fifties. A post surgery infection left me with a bad leg and needing a portable massage table. Normally I would have just built my own as I have a full shop and have built fine furniture as gifts for years. Unfortunately, my leg now limits me to a couple of hours a week in my shop, so I was resigned to buying a table. Doing healing work is a hobby and I could not justify spending \$800 for a top quality table with accessories. A friend let me use his spare table giving me time to find my own. I loved that loaner table, but was unable to find an affordable used one. I was led repeatedly to just building one of my own but struggled over how long it would take with my bad leg. With encouragement from friends I decided to build the best I could and share my efforts on the Internet. My design was done, but my table was far from finished when my loaner vanished. I had to have a table for an upcoming class. I bought a table from the firm who made my loaner table. After my purchase they hired me to do some web work, failed to pay, and stole my efforts forcing me to take them to court and win a judgment. Worse, an upholstery shop showed me two failed tables identical to the one I bought proving my new table was far lesser quality than my original loaner table. Regardless, this just inspired me to hurry up and build the table I really wanted.

### ***Table Type:***

Not one to want to reinvent the wheel, I researched massage table construction finding an incredible selection of many excellent solutions. Most of the nicest were stationary tables. One of my favorites was a heavy wooden table that tilted up turning into an oval mirror making a nice solution for a bedroom. There also were some nice light solutions including a sixteen-pound table made from plywood and aluminum and even a twelve-pound table made of

graphite fiber. Such fiber and tubes are now readily available and inexpensive enough to be an interesting possibility. Although I have the tools and skills to use aluminum or even graphite fiber, my goal was still to have portability and a design that others could build, so I limited my search to portable wooden framed tables.

### ***Table Design:***

The best tables share near identical time honored design elements and construction to make them comfortable for both the one giving and the one receiving a massage. This is a good balance between cost, weight, strength, beauty, noise, comfort, portability, and ease of use. All use a centuries old folding table design where the table skirt hides recessed adjustable height legs when the table is closed for storage. The tabletops are about 30" wide and about 76" long with rounded corners to minimize stretching while working on a client. Most are covered with two or more inches of foam with a built in face hole and padded table skirts with no protruding hardware. Like my grandfather's 1900's workbench, most use legs made from two mated pieces that are stable and easy to adjust with one threaded knob. All use center support braces with everything held locked firmly in place by strong steel cables that pull tight as the table is set up. This produces a strong rigid work surface with near instant setup and takedown without having to engage any locks, levers, knobs, screws, etc. This same design was used in the twenties to let airplane wings fold for storage and lock rigid in flight. All remove excess wood on the supports and legs to minimize weight. All strategically use padding and plastic washers to avoid squeaks. Elastic pulls the cables out of the way when closing the table. All woodworking is carefully rounded, sanded, and finished to protect surfaces and prevent snags. The only part of these designs that is newer than fifty years is the use of the new soft tough vinyl that can withstand body oils and acids, is easy to clean, and can be worked with a standard sewing machine.

### ***Quality:***

Long ago I learned the feeling of a good deal passes quickly when you have to live with poor quality. I always try to spend the few extra dollars to make something really special that I can enjoy and be proud of for many years. On a massage table there really is so little that the cost to do a significant upgrade is tiny. One of my sad discoveries is that many designs, including the one I bought, cut too many corners. Declining to follow their lead, I upgraded to furniture quality hardwoods with fine solid brass hardware. I threw out the commercial skirt designs with poor joints and staples that will come loose in favor of a single piece laminated plywood arch glued on a thin strong sheet of Baltic birch plywood. This construction takes a little more work but creates a much stronger and lighter solution that will last. A friend of mine who owns an upholstery business said that most lightweight foam only lasts a couple of years and strongly recommended use of the more expensive commercial upholstery foam. The small initial cost increase can save hundreds in replacing foam and upholstery every few years. I also replaced the fancy leg end

supports that bang into me when I use a knee pillow with a strong simple arch that I customize with a scroll-sawn name or design. For myself I also added two removable pillows that attach to the inside of the frame with Velcro, one for a bolster or head pillow, and the other a kneepad. I also added a Velcro held 1 1/2" thick fleece pad, elastic fitted sheet with a sewn in lined face hole, and polar fleece face hole pad to improve comfort. This far better quality only costs a few pounds of weight and a few dollars.

### ***Table Size:***

Buying standard "off the shelf" materials pretty much defines maximum table size within the above limits. Even part of an inch takes us from using standard materials into far more costly special order items, wasted material, and having to make complex splices, joints, and other compromises. Standard Baltic birch plywood is the strongest lightest affordable wood for the tabletop. It comes in 60" squares limiting the table width to 30" which is a half sheet. That 30" table width is further reinforced as commercial foam comes in 60" by 80" sheets and few firms will sell less than a half sheet. Foam is too expensive to waste and does not join well. Rounded corners pose a little more woodworking challenge and further limit the length of the table. Sawing a standard 1/8" x 48" x 96" (4' x 8') sheet of plywood into the long thin strips needed for bending to make the rounded corners creates 96" long pieces. When bent to create a 30" diameter circular arch for a 30" wide table, these pieces form a side that is just over 38" making a finished table length of 6' 4".

### ***Omissions:***

There are many clever features that can make a nicer table. There also were many features that took away from overall table life creating something that just would not last. Although most offered an auxiliary face cradle, I did not find any that were that comfortable or looked like they would stay in adjustment. A silly offering was a plug for the built in face holes that makes no sense when you can just turn the person around to keep the face hole out of the way. One other really nice comfort feature that just posed too much of a design and woodworking challenge, was making the table able to both tilt and fit different body positions allowing for adjustments to accommodate breasts, pregnancy, and sore backs.

## **Preliminaries**

### ***Cost:***

The typical cost to build one of these tables is about \$235 depending on where you shop and the quality of foam you choose. One of my students, a real scrounger, was able to build this table for under \$50 but figures he spent nearly one hundred hours scrounging. He scrounged most of the hardware from a commercial junkyard, used foam he found in computer packing boxes,

and got the wood from a railroad salvage yard. I do not have the time to do that kind of scrounging, so the items used in my table were found at my local Home Depot Warehouse store, Joanne's Cloth World, a cable store, an upholstery supply store, and a specialty wood store.

### *Time:*

As a hobby and in no hurry, my first table was a labor of love that took over a year to complete. Much of that elapsed time was spent working around my bad leg that severely limits my time on my feet, plus being very fussy. Although my mind was set on most of the basic features, it took a long while to research many tables to find the best way to make what I wanted then figure out how to do things and make the needed jigs. Once I had the right design, my table still had to have the right hardware and fine hardwoods. I spent much extra time machining, sanding, and finishing all to perfection. It also needed extra time for special inlay decorations, scroll-sawn designs, and healing stones.

Fortunately, many positive suggestions and experience helping my students build their own tables has this plan refined enough that most say they can build this table in about forty to sixty hours work over a few weeks elapsed time. Most spend about two hours building each side of the tabletop. The legs take about two hours more to machine. The braces also take a couple of hours to machine. Rounding all over with a router takes a couple more hours. About four to six hours of sanding followed by a couple of hours of finishing completes the woodworking. With drilling jigs to ensure consistency you can drill the holes for the hardware in few hours. The upholstery involves making five seams and only takes about two hours to sew and a couple of more hours to install with foam padding. Building the cables only takes a couple of hours but requires **a cable swaging tool if you do not want the table to collapse!** Cable measurements are critical and you can not finish the center cables until all is assembled so you can determine the right length. Cable suppliers will make the cables for about \$12 extra. It takes about ten hours to assemble the table, install the hardware and finish the center cables.

### *Getting Started:*

Read these instructions carefully before starting on your table. This Internet page has the benefit of feedback from many who have successfully built these tables trimming the cost, time, and frustration considerably. Pay particular attention to the areas regarding making cables and in cutting your wooden parts. For example, I found it far less trouble to let my wood store cut my laminating strips for the skirt, cut the Baltic birch ply in half for the tops, and cut the hardwood for the legs. They only charge \$10 for all of those cuts. Similarly, building a few jigs will save lots of grief. So will having lots of clamps (I use twenty-two to make the rounded end for one table half).

## ***Tools:***

To make the legs and top you need a set of hand or power tools plus a few specialty tools including: 3/4" and 2" Forstner drill bits, a router, a 1/4" lower bearing round over router bit, a 1/2" lower bearing pattern following router bit for trimming tops, a 1/2" flat bottomed upper bearing pattern following router bit for hinge recesses, glue "J" roller, and at least 8, preferably 16 clamps. A table saw, scroll saw, and chop saw all help to speed up the construction, but none of these are essential. All of the hardware can be installed with hand tools but you do need to cut four threads with a 1/4" 20 drill and tap. For the upholstery you need good and rough scissors, razor knife, single edged razor blades, electric carving knife, sewing machine capable of sewing light weight vinyl, and a heavy duty staple gun. A router table is a big plus and makes the wood working safer and easier.

## **Materials List:**

### ***Upholstery:***

- 2 ea. Medium-density upholstery foam 2" x 30" x 39" for table padding
- 2 ea. Carpet padding 1/2" x 30" x 39" for table padding
- 2 ea. pieces of 1" lightweight foam 6" x 96" for table side padding
- 3 yards x 54" of "Doeskin" Soft vinyl covering stretchable in all directions
- 1 ea. Elastic Cord 3/16" x 30" to pull cables out of the way during folding
- 1 ea. Tack strip 1" x 30' to hide vinyl edges

### ***Hardware:***

- 1 ea. Felt strips (self adhesive) 1/8" x 3/4" x 24" for cushioning leg tops, and sides
- 1 ea. Hinge brass plated 1 3/4" (or 2") x 24" for connecting table halves
- 4 ea. Hinges, 3" tapered strap hinge for mounting legs to table
- 4 ea. Cables 3/16" wire rope vinyl coated 16" long unfinished (no ends)
- 2 ea. Cables 3/16" wire rope vinyl coated 44" long (make after table completion)
- 12 ea. Cable ferule ends for making cable loops (Get spares and practice first)
- 4 ea. Cable races 3/4" x 1/4" with 1/4" ID hole upper cable support
- 4 ea. Cable dual-races 3/4" x 1/2" with 1/4" ID hole center dual cable support
- 8 ea. Tips, 3/4" Rubber or plastic for wooden leg bottoms
- 8 ea. Allen head bolts 2" x 1/4" 20 for upper leg cable mounts & lower leg center brace
- 4 ea. Allen head bolts 2 1/2" x 1/4" 20 epoxy in for leg center to attach lower leg
- 4 ea. Allen head bolts 4" x 1/4" 20 with 2" unthreaded for center support cable mounts
- 4 ea. High density plastic 3 1/2" x 3/8" dowels for quiet center supports
- 24 ea. Screws, brass plated hinge 1 1/4" for table center hinge
- 48 ea. Screws, Brass #6 5/8" for leg hinges & leg face supports



- 4 ea. Decorative knobs 1/4" 20 to hold lower leg to upper (must be thin)
- 4 ea. Nuts, cap type 1/4" 20 to hide end of top leg upper cable bolt
- 4 ea. Nuts, Aircraft non slip 1/4" 20 to press into lower center support
- 4 ea. Table leg extensions cushioned 2" x 1/4" 20 to stand table when it is closed
- 4 ea. T-Nuts wood press in 1/4" 20 to mount table leg extensions
- 16 ea. Washers, Nylon or high density plastic 3/4" OD 1/4" ID center support
- 8 ea. Washers, Steel 3/4" OD 1/4" ID cable supports
- 1 ea. Carrying Handle or heavy nylon strapping
- 2 ea. Draw catches, Brass 2 3/4" x 1 1/2" with screws to hold table closed
- 2 ea. Aluminum rod 3/8" x 14 3/8" both ends with 1/4" x 20 threads for center braces
- 1/4" and 3/4" staples

### ***Wood:***

- 1 ea. Wood Ply, Baltic Birch 6 mm 60" square
- 2 ea. Wood Ply end pieces 24" x 12" x 6 mm (or 1/4")
- 4 ea. Wood Ply under leg supports 6 mm (or 1/4") x 4 3/4" x 8 1/2"
- 4 ea. Wood leg, alder upper finished size of 20 1/2" x 1 1/2" x 1"
- 4 ea. Wood leg, alder lower finished size of 16 1/2" x 1 1/2" x 1"
- 4 ea. Wood Center Brace, HR maple top piece 23" x 1" x 3/4" (with groove - see drawing)
- 4 ea. Wood Center Brace, HR maple bottom piece 14 5/8" x 1" x 3/4" (with groove - see drawing)
- 14 ea. Oak Plywood Laminating strips to make sides, 96" x 1/8" x 2" (7 strips each side)
- 2 ea. Wood End Strip, hardwood 1" x 1 3/4" x 28 1/8" (table skirt end pieces for hinges)
- 1 ea. Wood Ply, 3/4" x 48" x 48" for forms/templates

### ***Supplies:***

- Wood glue, 16 oz. (Polyester or yellow aliphatic resin all weather glue recommended)
- 1 Can of upholstery foam spray adhesive
- Plastic drop cloth
- Clear plastic 2" package sealing tape
- Small tube of silicon grease
- Small tube of clear silicon adhesive

## **Construction General Information:**

Building this table is broken down into four parts. First, build the tabletops. Second, build and finish the legs and supports. Third, upholster the tabletops. And finally assemble the table and mount the hardware.

### ***Finishing:***

All exposed wooden edges are rounded over with a router then all wooden parts are sanded to 220-grit sandpaper optionally followed by 400 grit. Do not do any finishing until all gluing and machining is done. Although lots of different finishes have been tried, the easiest and best lasting appears to be a tough polyurethane wiping oil. Apply two coats to all exposed wooden parts except the tabletops and skirts prior to final assembly and upholstery.

## **Construction Detail:**

### ***Upper Legs:***

The wood for the legs must be a straight grained hardwood to prevent a leg from sheering or the holes from letting go when weight is applied. Cut the leg tops 1/16" oversize for length, width, and height. Now sand off the saw marks bringing the pieces to the correct finished size. Cut the hinge recesses using a jig and pattern following router bit exactly 1/4" deep. The recess stabilizes the hinge and is needed to let the table leg lie down flat enough to close the table! Preferably using a router table very carefully layout then cut the 45-degree bevels on each side without cutting into the top 3" of each leg. Although you only need to cut these 45-degree bevels on the outside of each leg to mate with the lower legs, cutting both sides looks better and saves weight. Next, drill the three each 1/4" bolt holes using a template and backer board. Now carefully create two left and two right legs. Each leg will have the upper and lower outside holes and inside center hole bored out to make an exact flush fit for the Allen headed bolts. A drill press or stop collar on your bit here is a must to keep from drilling to deep or ruining parts by the drill grabbing. Epoxy in the upper and center Allen headed bolts for the upper cable support and center lower leg support. Finish, then screw a hinge onto the top of each leg. Hold off on applying the felt on the top of the leg where it will touch the bottom of the table and on the bottom outside edge where it will mate with the lower leg.

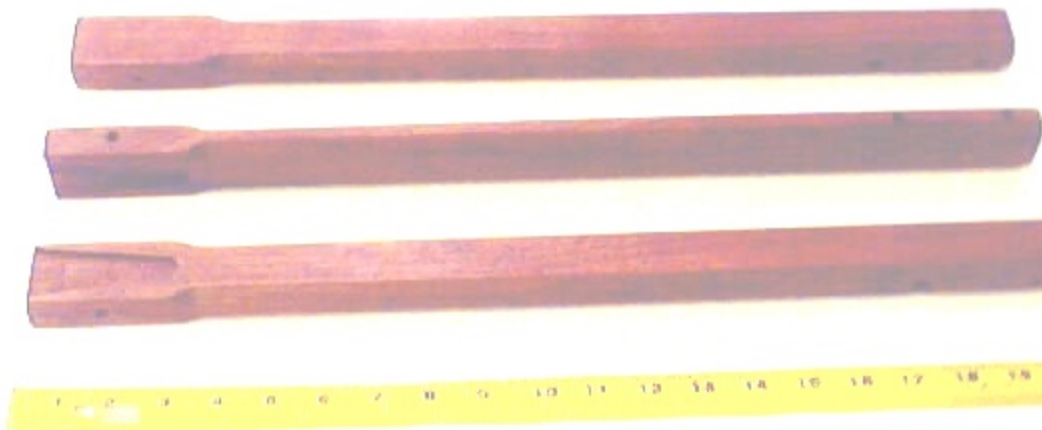
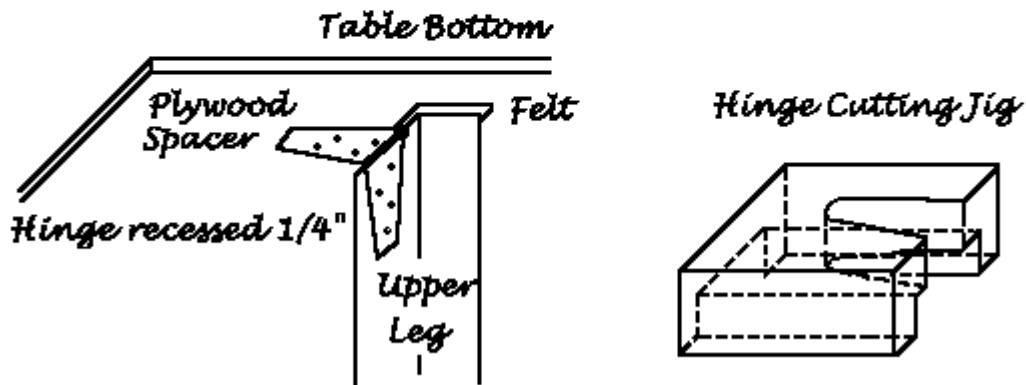
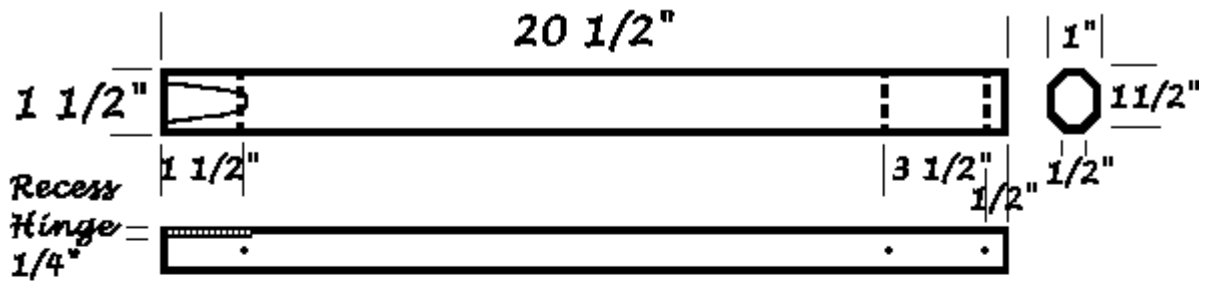

### **Lower Legs:**

Again carefully size 1/16" over for length, width, and height. Next, using a jig and preferably a drill press, drill the nine 1" apart 1/4" bolt holes drilling from front to the back using a tightly clamped backer board to minimize tear out. Next cut the bevel slots to match the top leg piece. This fit keeps the leg strong and stable, so considerable care should be taken to ensure a good mating fit with the upper legs. Start by carefully tracing an upper leg to show what material is to be removed from the lower leg. Setup your router table to support both sides and the top then use multiple passes with a 45 degree 1/2" router bit to cut that slot (if you are having trouble finding a 45 degree bit, just remove the bearing from a regular 45 degree bit). Alternatively you can make

these cuts on a table saw. Use several passes on a table saw to cut the center out followed by tilting the blade to 45 degrees to cut the groove sides. Sand and apply the finish. After the finish has dried hard, screw in two 3/4" rubber bumpers equally spaced into the bottom of each leg. Now apply felt to the top of the lower leg where it will mate with the upper leg. This felt will help keep the table from squeaking.

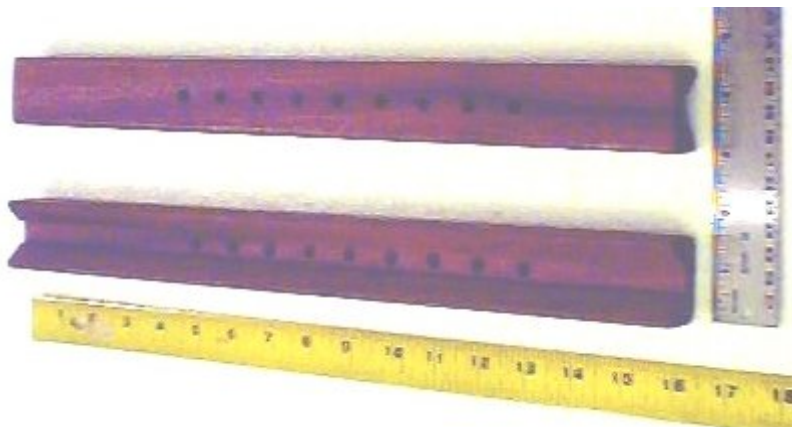
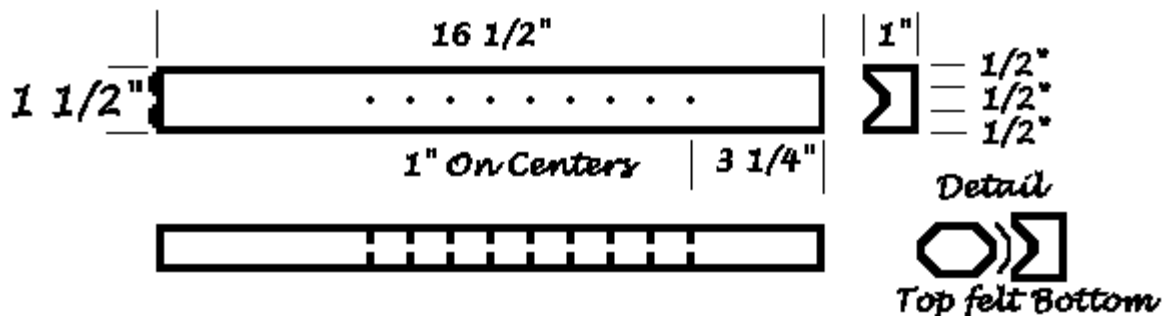

### ***Center Supports:***

There are four upper and four lower table center supports. Only a very strong straight grained wood such as hard rock maple should be used for these parts. All are made the same way. First size 1/16" over for length, width, and height. If weight is critical you can use a jig with your router to cut a 1/2" wide and 1/4" deep rounded groove on the upper and lower faces stopping the groove 1" from each end. Remember to make multiple light passes, as these are very small pieces. Sand to size and finish. Now use a jig with proper spacing and a 1/4" brad point bit with backer board to drill holes for the lower support board and the lower hole for the upper support. Again use a jig and a 3/8" brad point bit with backer board to drill the plastic dowel holes in the upper supports. As was done for the top leg, carefully drill the recesses in the lower center support braces for the Allen head nuts. Measure the widest dimension of one of your 1/4" 20 aircraft nuts. Pick a brad point bit that is 1/16" under that size. Use either a drill press or stop collar then drill on the side opposite the Allen head a recess deep enough so the aircraft no slip nut will fit flush. Screw in a bolt to

ensure the aircraft nut stays properly aligned and press one into each of the four lower center support brackets until each is just flush.

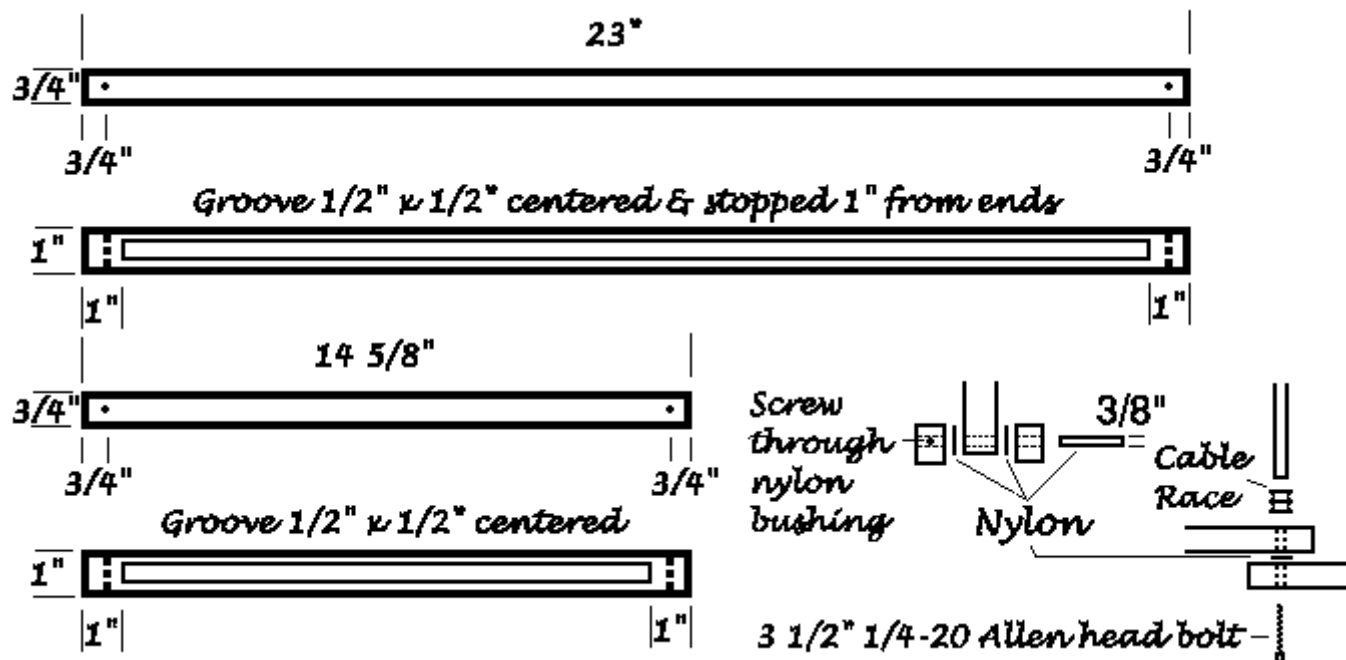

### Cables:

The six cables used in this table make up the many triangles that keep this table strong. Using the wrong type of cable, the wrong kind of cable ends known as ferules, or even the wrong tool to crimp those ends will make weak cables. Of the many different kinds of cables (called wire rope), 3/32" cable coated with an extra layer of vinyl to protect the woodwork works best for me. You can use either stainless steel or not, but it is important that you have a high wire count for ample flexibility and at least that thickness for the proper strength. You can make up all four upper cables in advance, but should hold off on completing the final end on each bottom cable until final assembly, as there are too many variables to know the exact final length in advance. Holding off to make these lower cables will fix any tiny variances. To size those lower cables and have them have just the right tension, I turn the table upside down and set the cable length to hold one end flat and the other just 1/4" off a flat floor then build the other cable to the same length.

Putting the loops on cable is not difficult, but you must have the right parts, tools, and know how if you do not want the cables to fail. I learned the hard

way when my daughter jumped on a table and it collapsed because a cable end let loose! Almost every part used in cable making is non-standard, so you have to measure carefully. Next you have to cut the cable which is easier said than done as good cable dents regular wire cutters. Use of anything but a good cable cutter makes the cable ends so frayed it is near impossible to put on the ferule ends, so you should either buy or rent a good cable cutter. You can easily spend \$50 on a good set of cutters. Mine work fine and cost under \$10 from [Harbor Freight Tools](#), or you can buy a good pair of Channel Lock brand cable cutters for about \$20. After stripping off 3 1/4" of vinyl coating pass one end of the cable through a ferule which is a little oval metal figure 8 shaped tube, around the cable race, then back through the other half of the ferule (easier said than done as this stuff is springy). Don't forget the race because the cable will be too tight to put it on later! You must use plated copper ferules as the aluminum ferules carried by most hardware stores are too light and will slip when weight is put on your table, so **don't use Aluminum ferules!** Tinned copper ferrules are available from cable supply stores (check out boat or marine stores if you can not find a cable shop). Making the crimp on the ferule just right requires a special tool known as a swaging tool. Cooper makes a good swaging tool for \$29, but again you can easily spend \$90 or more on one of these tools. Regardless, you need to use one or your cables will slip. Fortunately, most local cable suppliers and boat supply shops will let you use their swaging tool for free at their facility, if you buy cables and ferules from them. Sadly you need to make more than one trip as you will not know the final lower cable length until your table is built.

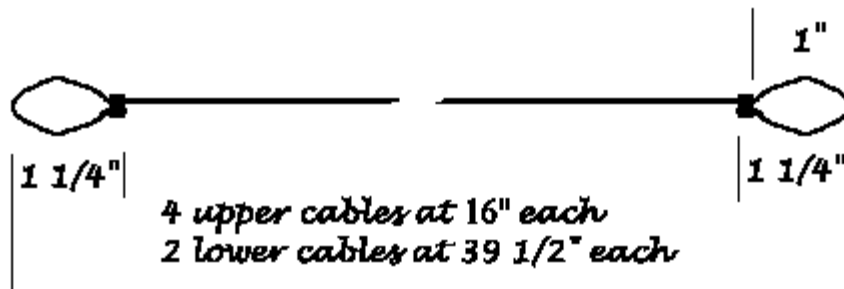

### ***Cable Races:***

There is a cable race at the top of each leg and a double race mounted on the ends of the support bar that goes between the center support brackets. These races look like the roller inside a pulley and let your cable sit firmly in a groove. I am still looking for a mail order source, so just made my own from some 1/4" 20 brass knurled nuts I found at my hardware store. Before finding these nice brass units, I used to make them from 3/4" washers and spacers.

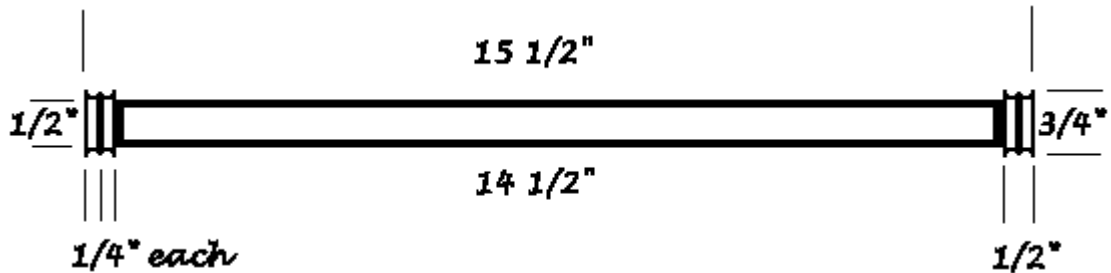

### ***Support Bars:***

You have to drill and tap with a 1/4"-20 thread 1 1/2" into each end of your aluminum support bars that go between the center support brackets. After threading I screw each rod onto a bolt chucked in my drill press and use sandpaper to make a nice brushed aluminum finish.

### ***Table Sides & Top:***

After seeing a few failed tables because they were made with stapled construction that came apart after a few years use I came up with a technique to build a stronger lighter table top. Mine makes the table skirt from thin pieces of plywood that are glued together in a lamination at the same time as they are glued to the plywood tabletop. This skirt glue-up process can be a messy nightmare if not properly organized. Key is having the right glue, having all prepared in advance so you can finish before the glue dries, and having the right gluing frame jig that serves as the bending pattern you need to make your table skirt.

The tabletops are made from a single piece of 60" square 6-mm Baltic birch plywood that is about 1/4" thick. Less thick wood has just not worked out for others. I let my lumberyard rip that sheet in half making it easier to handle. After ripping, each half ends up being 29 15/16" wide or about 1/16" less than the finished width. Rounding over the edge with a router makes up the difference. This leaves no room for error, so the lumberyard must be right on center when they rip that plywood! At first I carefully precut the arch on the tabletops and spent a lot of time to get all to fit because of the cumulated errors in plywood thickness, gluing clamping pressure, etc. A much better way turns out to simply cut the arch a little oversize then trim it perfectly flush later after the glue up process with a lower bearing pattern following bit in your router.

The table skirt supports each table half and provides the mount for the hinge that connects the two table halves. I found that building each table half goes much easier if I start by gluing on the centered end pieces to provide a baseline for the later gluing of the plywood strips to make the single piece skirt lamination. To provide plenty of strength I make the skirt from glued together strips of 1/8" oak plywood. Each side takes seven 96" long 1/8" thick strips pieces carefully sized at 1 7/8" wide which after sanding finishes to 1

3/4" wide. These strips have to be even in width or they will not clamp tight and create a poor glue joint. I found cutting a 4' x 8' piece of 1/8" flexible plywood into exactly even strips on my table saw too awkward for good accuracy, so now just let my wood store make those cuts for \$0.50 each on their panel saw and the results are near perfect.

Key to the glue up process is having a gluing frame that is a jig that sets on the tabletop and provides the pattern to bend the laminations around. This jig is made from a piece of 3/4" plywood. It is 28 1/4" wide, which is the 30", table width less the two 7/8" laminated sides. It is 36 1/8" long, which is half the 6' 4" table length minus a 7/8" arch and 1" hinge mount. I carefully glue on 1/2" raiser blocks on one side of this frame. They are spaced exactly the width between the legs and provide a template for later making the leg end pieces. Mark on this jig a centerline down the middle of that jig that will be used for cutting out the face hole template and for ensuring the lamination strips are centered. Using a router cut the upper table half-circle, then using the dimensions cut out the face hole in this jig. Cut 2" clamping circles one inch in from the sides starting at the center evenly spaced all around including the base. Put 2" wide plastic tape all around the edge of this frame leaving an overlap both top and bottom to keep any spilled or overrun glue from sticking to the frame.



There is so much to glue that you have to move quickly or your glue will setup before you are done. To give you a little more time and to provide a lubricant for the lamination strips to slide against one another as they are bent, it is a good idea to use lots of glue. With lots of glue and working quickly this process is messy with lots of squeeze out, so take the trouble to use a drop cloth and mask all the unglued surfaces. You get the line for masking on the inside of your tabletop by lying the gluing jig against the already glued on



base and trace a line. With that jig still in place use a 1" block spacer to trace another line 1" outside the first to show where to cut your top. Also trace the face hole from your gluing jig on just one half of your table. Remove the jig and cut outside of that second line being careful not to waste the extra material as almost all of it is needed to make the leg end pieces and leg supports. Now Mask even with that the inside line followed by clamping the gluing jig to the table end piece.

Start your laminations by laying out all seven laminating strips together and put a centerline on them. Now mask two good surfaces that are to become your inner and outer skirt edges ensuring no tape is on the surface that will be glued to the tabletop. Get appropriate wet or solvent covered rags and keep them handy. I have my drill with countersink all ready to go and also use rubber gloves. Next evenly put these strips flat next to each other on a drop cloth and lightly spray with a mister to slightly dampen the wood. This helps with both yellow and polyurethane glue. I use a large old plastic mustard squeeze bottle to help me get the glue on quickly. Once I get the glue on those laminations I use a glue roller to spread the yellow glue and a small block of wood to spread the polyurethane glue. If you use yellow glue you need a thick coat on each surface. Polyurethane only requires a coat on one surface, so I prefer it as it is faster, plus expands to fill in problems. Regardless, the process is pretty much the same quickly building up an even stack of glued laminations being careful to have your masked surface on the top and bottom of that stack.



Before the lamination glue sets, quickly put a coat of glue all around the edge of the tabletop, the ends of the hinge piece, and on the edge of your stack that will be glued to the bottom of the table top. Pick up the stack of laminations and center it on the center of the gluing frame. Use a clamp to pull the stack flat against the tabletop then a C-clamp to pull your laminations tight to the center of the gluing frame. Using hand squeeze clamps to pull the stack to the tabletop with padded screw C clamps to bend the stack works best for me. Put

your next clamps on either side next to that center clamp to begin the bending process. Continue to quickly add clamps moving outward from that center clamp allowing the lamination strips to slide as each takes a different radius. Ensure your clamps pull the laminations flat to the table and to the gluing frame as you move outward. If you do not work from the center out, the stack will not bend correctly and you will have ripples. After the laminations are clamped, I remove my gloves then drill, countersink, and screw two 3" long tapered deck screws into each corner through the laminations into the hinge centerboard to add extra strength to each corner. Originally, I did not glue on the end pieces until later as I went to a lot of work making dovetailed joints in the laminations that mated with the end piece. A few people who made this plan convinced me this dovetailing was too much work for something that was both hidden and unnecessary. The deck screws and glue make for every bit if not a stronger joint. If you are not comfortable with this, you can glue in corner blocks. After the glue has set but before it gets hard, remove the clamps, the gluing frame, and masking tape. There now should be staggered stair step ends on all of the lamination pieces after this glue up hanging past your end piece on both sides. Let them be until the glue has dried hard.

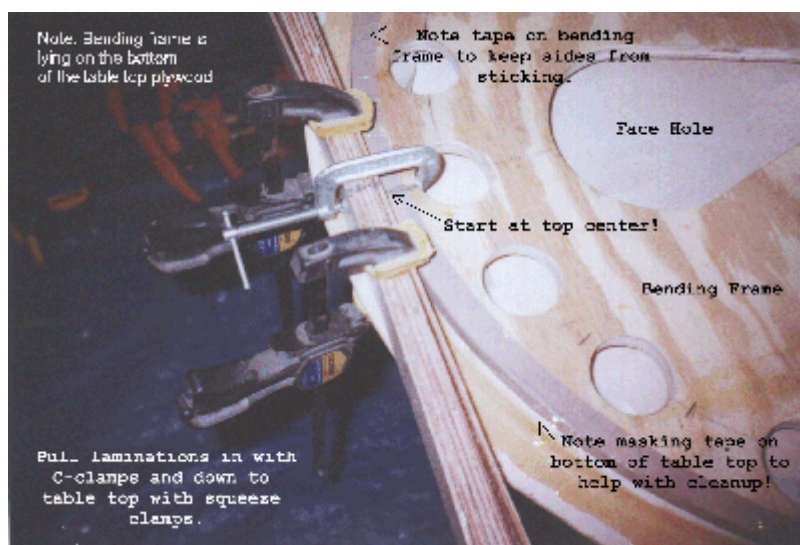
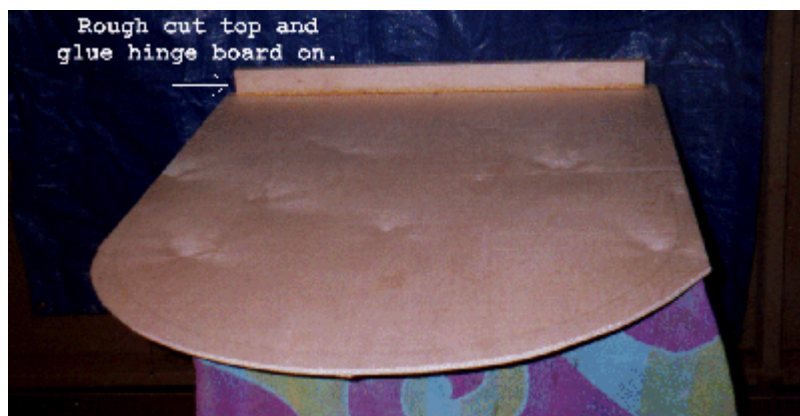

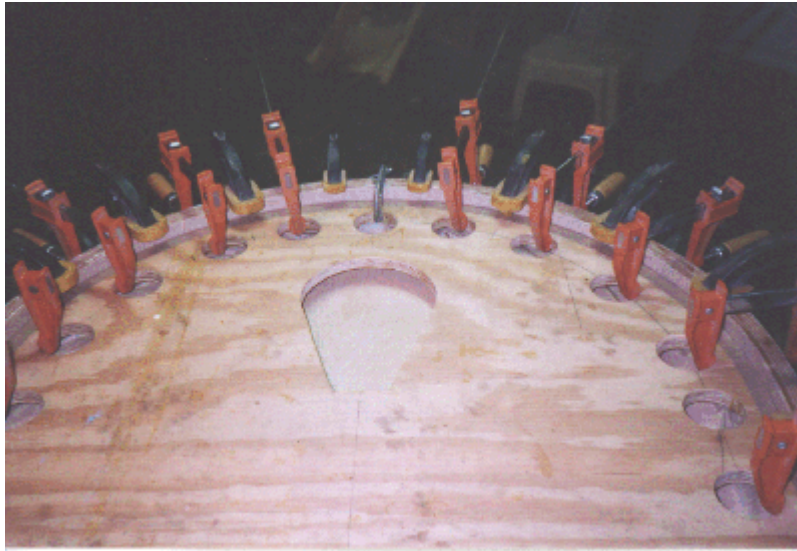

After all is dry, flip the top right side up. Saw the staggered lamination strips off leaving them a little proud (about 1/16" oversized). Use a pattern following router bit with a lower bearing to trim off the end pieces and to size the top to exactly match the frame. Use a saber saw to cut about 1/8" on the inside of your face hole. Clamp the gluing frame to your tabletop, flip the table upside down then use that same pattern following bit to evenly trim the face hole just perfect. Now use a 1/4" rounding over bit with bearing to round over the tabletop edges and the corners of the table. I then put a 1 3/4" spacer block on the edge of my router which lets me use that same bit to also round over the table skirt and end piece inside and outside edges without wobbling. This only builds one half, so repeat this process once more for the other side.

## **Upholstery & Padding:**

### ***Vinyl Type:***

Key to working with vinyl is having the right material. The old style heavy-duty vinyl used for restaurant upholstery is just too thick to work without commercial equipment and the really light tablecloth stuff is too thin to last. Also, many of these products have a backing that only allows the vinyl to be stretched in one direction making for at best a sloppy job trying to stretch around the table arch. At first I used heavy upholstery vinyl and really had to fight it using a heat gun. That problem went away after going to the more expensive doe skin vinyl. There are a few brands of this kind of vinyl, but the one I use is called Amatron.

### ***Vinyl Layout:***

After some sanding cleanup, before applying padding you need to use the tabletops as patterns to cut and sew the vinyl for an exact fit. Lay your three yards of vinyl good side down. Put both tabletops on that vinyl with the hinge sides toward each other spaced 18" apart as that saves a seam as the top can just wrap around the end and back up the inside of the skirt. Leave ½" extra on the lower edge. Careful! This is the only orientation that ensures you have enough material needed to cut the long side coverings! Use a marker on the vinyl backing to trace right next to the table skirt and the face hole to make your sewing and folding lines. Then make your marker 1/2" thicker (masking tape, spacer, etc.) and again trace around your table skirt as well as the face hole to make the cutting line. Don't forget to leave 9" extra material for each side as there are no seams at the center of the table as the vinyl top just goes from the top to wrap down the side! Now mark two 10" by 97" strips for the sides. I use a taper on the end of each of those long strips tapering the last 18" a half inch to make for a tighter fitting top. Mark a face hole liner that is ½" wider than the thickness of your foam and padding and one inch longer than the perimeter of the face hole. Caution! The 10" side width and face-hole liner strip widths might have to be adjusted if you use a different thickness of padding. Mark an identical face hole on a 12" x 12" vinyl piece to be used as an anchor for the bottom of the face hole strip.

## *Vinyl Cutting Diagram*

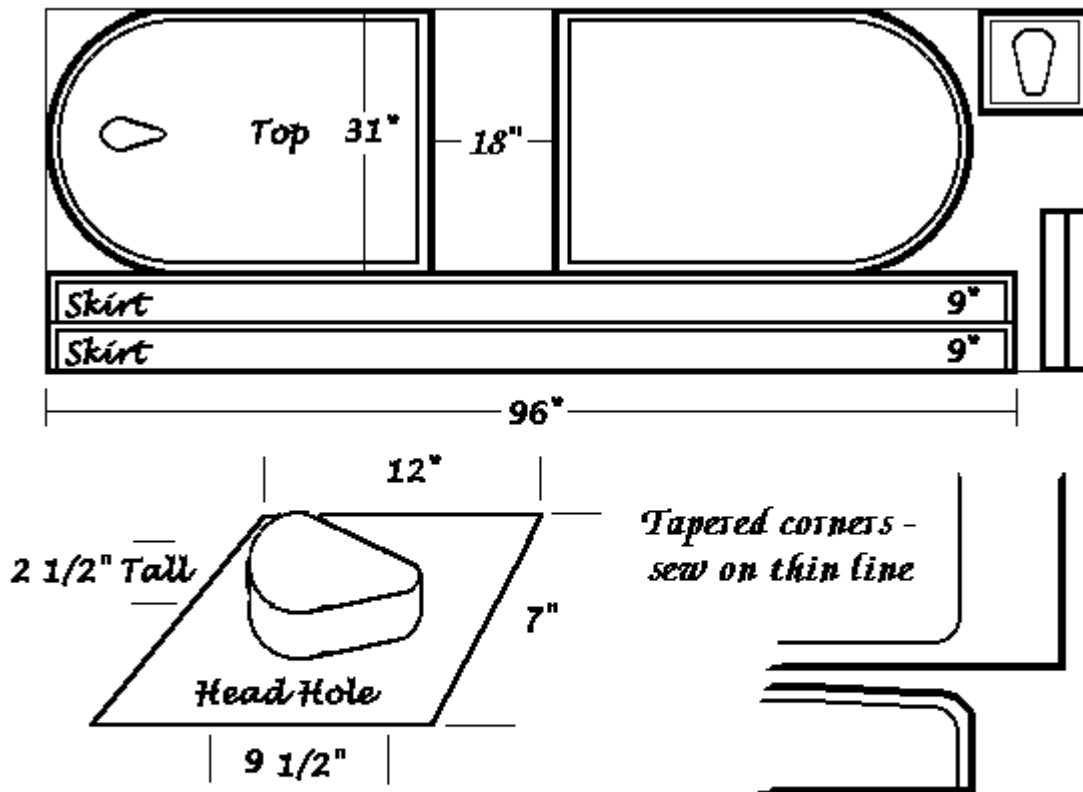

*Bottom piece to  
tack on underside  
of plywood.*

*Note: leave 1/2" extra material for seams.*

### *Padding:*

Be careful on the quality of foam you use in your table. Common lightweight foam is just too light to be workable. Light upholstery foam is a little heavier and will work, but will only last a couple of years. Sadly, many commercial tables use this type of foam and call it medium foam because it is less expensive. Using real medium density upholstery foam will add a couple of pounds, but will help the table padding and upholstery to last for years and years.

### *Pad Installation:*

After many frustrations and considerable help, building the padding for this table evolved from a four or five-layered complex task to a simple two-step

process. First use Hi-Tack foam spray adhesive to glue down a 1/2" piece of carpet padding and trim it flush with the table perimeter. This protects from ever pressing against an unprotected sharp or hard edge. Then carefully center and glue again with the Hi-Tack a 2" thick piece of medium density upholstery foam to the tabletop leaving exactly 1/4" overhang at the back of the table where the table halves will meet. With a standard 30" width foam piece the sides should already be flush leaving only the arch left to cut. Cut the foam using an electric carving knife or foam cutter. Be steady and careful as any jagged cuts show through the vinyl, particularly on the face hole. Cut the arch by holding the carving knife blade tight to the skirt to make a dead even vertical flush cut with the skirt. Then use a 1/2" spacer with a riser and tail to make sure you stay vertical when cutting the face hole. That spacer will follow the face hole to leave an extra 1/2" of foam overhang all around the face hole to provide more padding for the face hole. Next flip the table over onto its top and glue a 6" wide 1" thick piece of lightweight foam all around the skirt perimeter except for the ends where the hinges mount. This foam will be automatically be flush with the top. Using the electric knife and 1/2" spacer to trim the extra foam off the bottom edge of the sides leaving a foam overhang that will be rolled over with the vinyl to provide more cushion. This side foam provides added protection so nobody can press through the foam to hit wood.

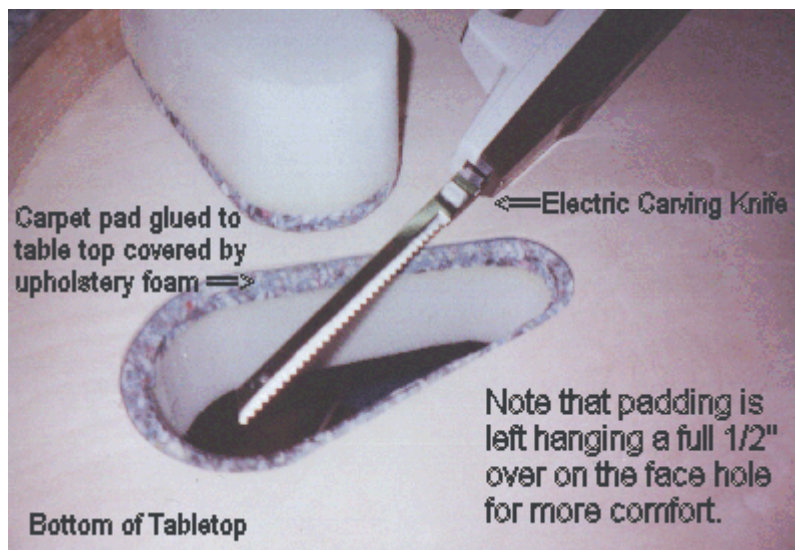

### ***Vinyl Cut Out:***

Measure twice and cut once! Having pre-marked your pattern, all that is needed is to finish marking the ends opposite the arch and putting in a little taper and some curves to make the vinyl lay better. You saved a seam by leaving extra material on the end to fold under. Go ahead and cut out your vinyl. After cutting, wrap the skirt side strips around the table skirt then carefully mark the skirt ends as a reference for the sewing and final cutting lines.

## ***Sewing:***

Start with the face hole. The face hole is made up of a strip of vinyl sewn to both the cover top and to a 12" square on the bottom that serves to anchor the vinyl. Use of that square is important because any wrinkles in the face hole caused by pulling the vinyl too tight are uncomfortable and leave wrinkles on the faces of those who will use your table. The width of this strip is  $\frac{1}{2}$ " less than the thickness of your foam padding plus  $\frac{1}{2}$ " on each side for sewing. For two inch foam you would use strips that are 2  $\frac{1}{2}$ " wide and have  $\frac{1}{2}$ " sewing seams. A few have said it is easier to sew this strip as two pieces, but most feel that having one seam centered in the chin position makes a more comfortable table. Start by sewing the strip to the tabletop. Next sew the seam at the center of the chin position. Finally sew on the bottom 12" square anchor piece. Make sure all seams are inside touching the padding. Next sew the table covers. Sew the skirt around the outside of each table cover starting with a  $\frac{1}{2}$ " overlap in one of the square corners. The little taper on the side strip will automatically build a pocket for the hinge edge of the table.



## ***Installing Upholstery:***

The two sides of the table are covered almost identically, except for one has the face hole. Because this is a fairly tight fit, it is best to work in a warm room where the vinyl is more flexible and to use a technique similar to rolling a sock on so all lines up just right. Carefully slip the covers onto each table half beginning with the hinge end that has that natural pocket. Then roll the skirt down over the rounded part of the table getting the upholstery nice and even. Use your hand or something smooth to make sure all of the seams are pointed down both around the table edges and the face hole. After the face hole is centered, carefully staple the anchor pad for the face hole using short staples making sure it is a smooth even fit. Your face hole will be the guide to show you how much to stretch the rest of the vinyl. Now work from the center

of the arch going outward pulling that vinyl tight and stapling it in place to the laminated skirt frame. Work from one side to the other from that center point making for a nice even job. Use a tack hammer to make sure all the staples are in flush then use a single edged razor blade to carefully trim the excess vinyl right even with where the skirt joins to the top.

### ***Table Assembly:***

First build your leg end assemblies. Start by clamping a left and right leg to the leg spacers on your gluing frame. Put a little glue on each corner of your leg end pieces then screw down to those legs. Unclamp the leg end piece and using an Allen wrench mount the upper cable support bolts with cables. Mount the lower center support bars using a plastic washer between the center support and leg screwing to the recessed aircraft nut. That nut was pressed into place so it should not turn. Now put the lower piece of felt on the upper leg assembly just covering that lower hole used to mount the lower center support brace.

Now build and install the upper center support brace. Put the plastic hinge rod through the top of the upper center support braces. Put a plastic washer on each side of that plastic hinge rod. Next press on tightly a wooden block on each side of that rod. Drill a screw through those wooden support blocks so each just goes through the plastic hinge rod. Now mount this upper center support assembly to the leg assembly. This involves first running a long Allen headed bolt through the lower support bar, then a plastic washer, then the upper support bar, a steel washer, then your two cable races with both upper and lower cables installed, then finally tightly into your threaded aluminum rod.

Next join the table halves. Place the table halves end to end bottoms up and tightly clamp the two end pieces together. Next carefully measure and center the 2" x 24" center support hinge. Pre-drill and install the screws. Putting a little wax on these screws before driving helps lots! Then release the clamps.



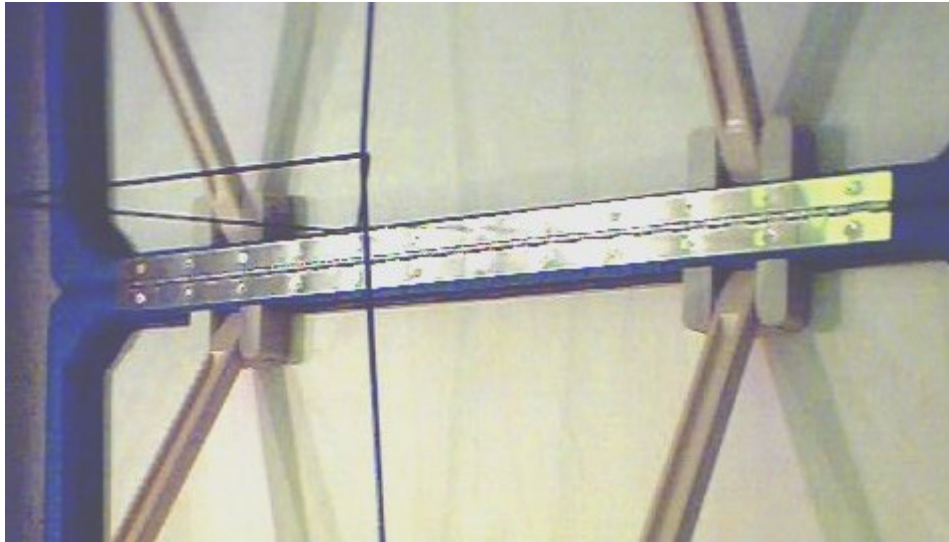

Next mount the leg assemblies. Fold the leg assembly up as it will sit when the table is closed. Carefully mark where the upper center support braces are to mount. Use silicone glue on the bottom of those center support mounts, clamp them tightly in place and screw them to the table center pieces using long deck screws. Slip the quarter rounded hinge support plywood pieces under the leg hinges roughly where each will go to give each hinge to give ample support. Carefully mark on the hinge support pieces where the hinges are to be mounted. Screw the leg hinges to the still loose hinge support blocks ensuring you do not go through the tabletop. Apply glue the bottoms of those hinge support pieces, fold the legs completely closed, center then screw the blocks and hinges in place.



Now measure and install the last two cable ends. With the table upside down, you will have to elevate one end of the table about  $\frac{1}{2}$ " to ensure the cables will be tight when the table is deployed. Take the loose end of the one available cable, wrap it tightly around its race and mark the center. That center is where you will have to center your  $3\frac{1}{4}$ " loop. Add to that center  $1\frac{5}{8}$ " and cut your cable. Measure the result and cut the other cable to exactly match. Strip off  $3\frac{1}{4}$ " from each cable, apply the ferrule ends, and swage the ends on. Tie the elastic into a loop and run the two loose long cable ends through that loop. Undo the center races and install those new ends. Screw the elastic using a washer to the inside edge of one table half. Apply the 1" tack strip to finish the whole inside edge as well as the face rectangle. Mount the closing clasps. Use a rope with a large knot in your closed table to find the balance point for your carrying handle. Center the handle on that balance point. Use and enjoy!

## Diagrams:

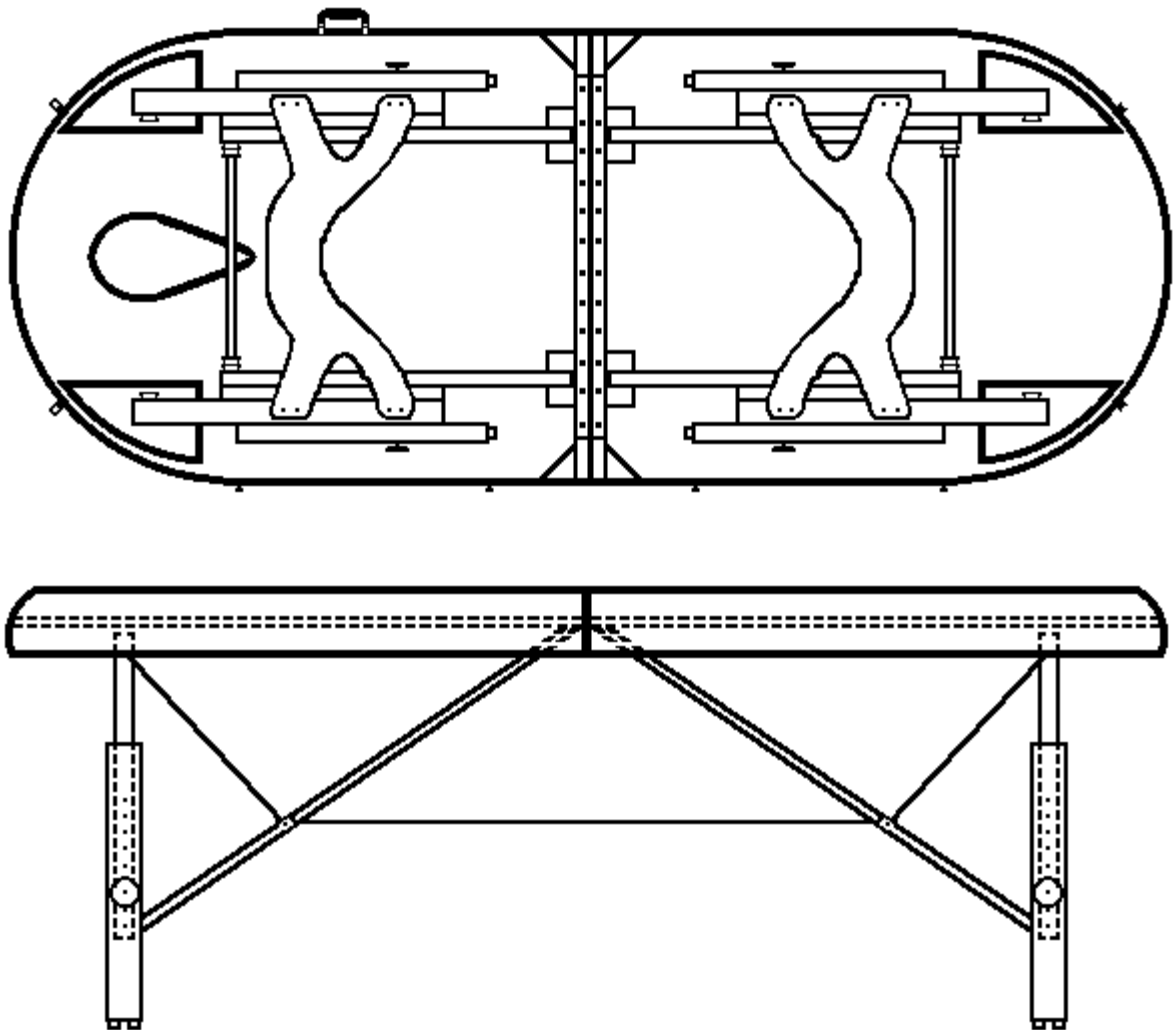

Face Cutout Detail

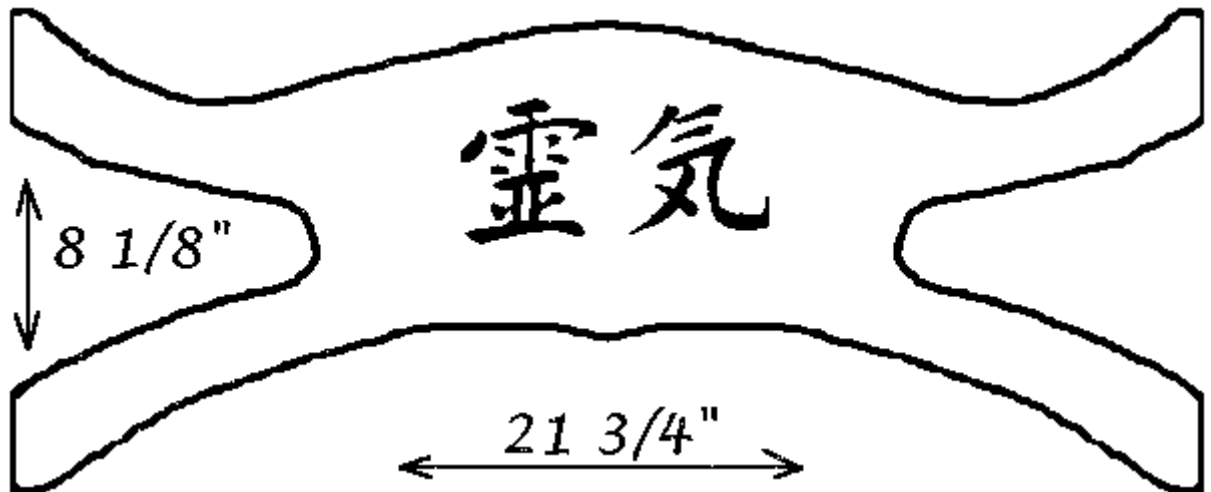
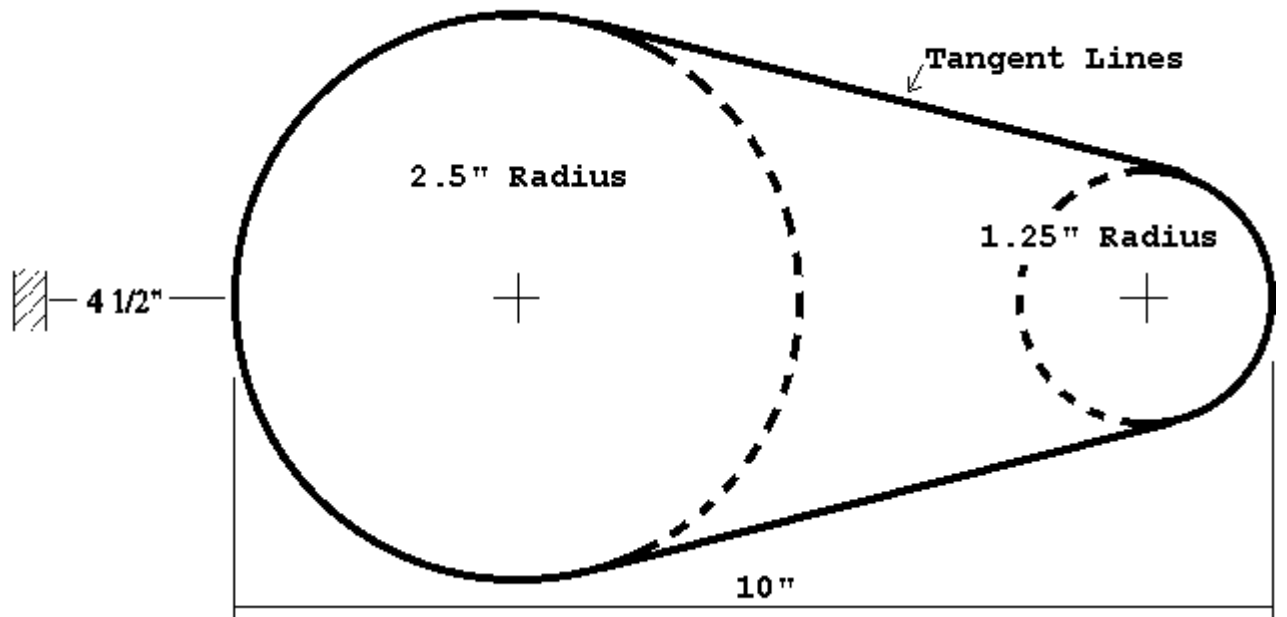

# Imperial to Metric Conversion Table:

Inch	cm	cm			
1/8	0.32	0.32			
3/16	0.48	0.48	<b>Imperial to Metric Conversion Table</b>		
1/4	0.64	0.64			
3/8	0.95	0.95			
1/2	1.27	1.27			
5/8	1.59	1.59			
3/4	1.91	1.91			
1	2.54	2.54			
1 1/4	3.18	3.18			
1 1/2	3.81	3.81			
1 3/4	4.45	4.45			
2	5.08	5.08			
2 1/2	6.35	6.35			
2 3/4	6.99	6.99			
3	7.62	7.62			
3 1/2	8.89	8.89			
4	10.16	10.16			
4 3/4	12.07	12.07			
6	15.24	15.24	1/2 foot		
8 1/2	21.59	21.59			
12	30.48	30.48	1 foot		
14 5/8	37.15	37.15			
16	40.64	40.64			
16 1/2	41.91	41.91			
20 1/2	52.07	52.07			
23	58.42	58.42			
24	60.96	60.96			
28 1/8	71.44	71.44			
30	76.20	76.20			
36	99.06	91.44	3 feet	1 yard	
39	99.06	99.06			
44	111.76	111.76			
48	121.92	121.92			
54	137.16	137.16			
60	152.40	152.40			
96	243.84	243.84	9 feet	3 Yards	2.7432 meters